



February 29, 2024

Chiller Replacement Project – St. Augustine Campus (BID-SJR-13-2023)

The following changes, additions, and/or deletions are hereby made a part of the Construction Documents for the above noted project. All other terms, conditions, and specifications of the original Invitation to Bid remain unchanged.

Note: Acceptance of this Addendum must be indicated in Contract and/or Bid Form submitted as part of the submittal package.

ADDENDUM No. 1

All items in this Addendum are incorporated into the Contract Documents.

Item #1.

List of attendees at the Pre-Bid Meeting on January 25, 2024, at 9:30 a.m.:

Terry Thomas, St. Johns River State College
Gregg Gunderson, St. Johns River State College
Mike, Canaday, St. Johns River State College
Tom Reynolds, St. Johns River State College
Chad Robinson, SGM Engineering
Paul Shealy, Scorpio
Stephen Burdette, ABBA Construction, Inc.
Rich Dorau, Foresight Construction
CJ Wildasin, Cortez Heating & Air
Chad Barnett, Coker Industrial Contractors

Attendance Register included as **ATTACHMENT A.**

Item #2.

Questions Received after mandatory Pre-Bid Meeting:

Question #1: Our continuing contract with SJRSC has a requirement for 'Owner's and Construction Manager's Protective Liability Insurance'. This requirement has been waived in the past, please confirm if it will be required for this project.

Answer #1: For minimum insurance requirement schedule please refer to 00 73 00 Supplementary Conditions for All Insurance Requirements.

Question #2: Can another site visit be scheduled?

Answer #2: Yes, you can schedule additional site visits by calling one of the following numbers.

Gregg Gunderson 386.312.4093 email: gregggunderson@sjrstate.edu

Mike Canaday 386.312.4091 email: mikecanaday@sjrstate.edu

Tom Reynolds 904.276.6763 email: tomreynolds@sjrstate.edu

Tim Mouse 904.808.7472 email: timmouse@sjrstate.edu

Question #3: Discrepancy noted on the award timeline for Electronic Posting of Bid Results & Notice of Intent to Award. What is the correct date?

Answer #3: The correct date for the Electronic Posting of Bid Results & Notice of Intent to Award is February 29, 2024, after the public meeting to open bids which occurs at 2:30 p.m.

Question #4: Please clarify if the Owner is providing any of the mechanical equipment. I asked this question in the pre-bid meeting and the answer was "no" but several subcontractors are hearing that the Owner is providing some of the equipment and we would just like to have this answered in an addendum. If the Owner is providing some equipment, please specify which items and provide lead times.

Answer #4: No. The owner is not providing any equipment for this project.

Question #5: Ref. M002, Mechanical General Note #23: This note states that the contractor is to flush the entire chilled water system. Please provide a schedule showing the quantities, locations and types of equipment (Ahu's, fans, etc.) that have coils that will require bypass lines, and which are at floor level or ceiling mounted.

Answer #5: Flush only the new chilled water and condenser water pipes prior to connecting the new equipment.

Question #6: Please clarify when outages will need to be scheduled for tying in new piping to existing system (after hours, weekends, summer months?).

Answer #6: Outages for tie-ins should be scheduled on weekends. Note: the SJR State weekend schedule for the months of May, June, and July includes Fridays, Saturdays, and Sundays.

Question #7: Ref. M002, Mechanical general Note #10: This note states that chillers, pumps and cooling tower shall remain property of the Owner. Please clarify if the Owner will transport the old to a certain location or if contractor will be responsible for transport. If the contractor is to transport, please clarify the location where the equipment is to be transported.

Answer #7: No. The owner is not claiming nor retaining any existing equipment so designated to be demolished on this project. The contractor shall remove from the site and dispose of all.

Question #8: During the site visit, it was noted by the engineer that there may be some conflicts with the location of the new cooling tower as currently shown in the bid documents. When can we expect an addendum that addresses this issue?

Answer #8: February 27, 2024.

Question #9: Will temp cooling be required?

Answer #9: Temp cooling not required. Coordinate shutdowns with owners.

Question #10: Per mechanical general note #5 on M002, will all exposed piping need to be painted?

Answer #10: All exposed (non-insulated pipe to be painted.

Question #11: Does the existing refrigerant monitor system support both R-134a and the new chiller refrigerant?

Answer #11: We will need to provide a new refrigerant monitor for the new refrigerant, but we would tie it to the existing exhaust fan. This would require a drawing change.

Question #12: Confirm we specified black steel for the pipe and not HDPE.

Answer #12: Black steel pipe confirmed.

Question #13: Confirm the chiller warranty from the manufacturer.

Answer #13: Confirmed with manufacturer that the warranty offer is 10-year parts and labor.

Question #14: The new cooling tower seems to overlap a little on the driveway into the CEP. We may need to add notes to the drawings to cover scope to modify.



Answer #14: We will add keynotes as part of Addendum No. 1 to cover this expansion.

Question #15: The existing tower does not appear to have an equalizer pipe connection, or it was piped incorrectly (see photo below).



Answer #15: Confirmed the existing tower is piped incorrectly to support a second cooling tower. We will need to re-pipe in order to correct. Unfortunately, this will mean that the existing chiller will have some down time. This should be minimal if as much pipe is preinstalled and the final connections coordinated with college's schedule to avoid affecting the campus.

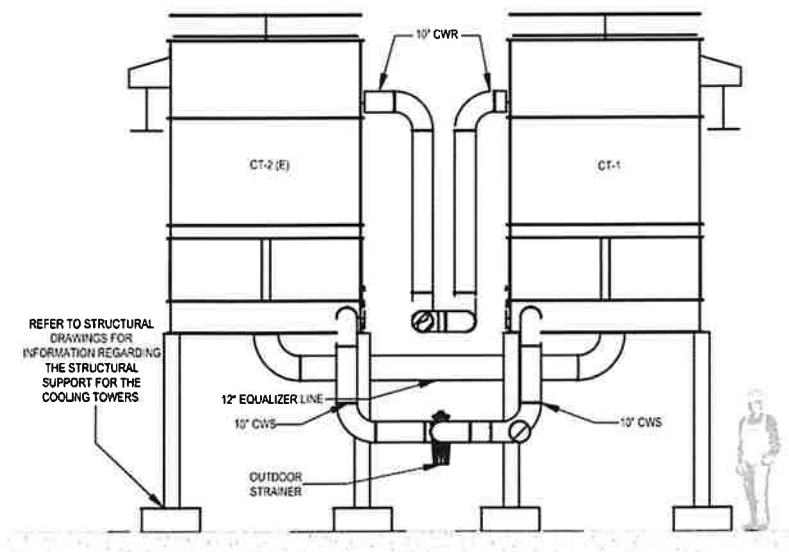

Question #16: Add a note to the chemical treatment that the provider is to be Nalco.

Answer #16: Note will be added under Addendum No. 1. Drawing change required.

Question #17: Add a note to the controls keynote to match the existing provider onsite.

Answer #17: Note will be added under Addendum No. 1. Drawing change required.

Question #18: What is the weight of the cooling tower that is being removed?

Answer #18: Found information from the Tower Tech owners O&M manual. See below. This cooling tower has been in service since 1996, the actual weight of the cooling tower due to a build up of solids is almost impossible to determine. The Owner's manual recommends removing some or all existing plastic fill material to reduce the weight of the tower.

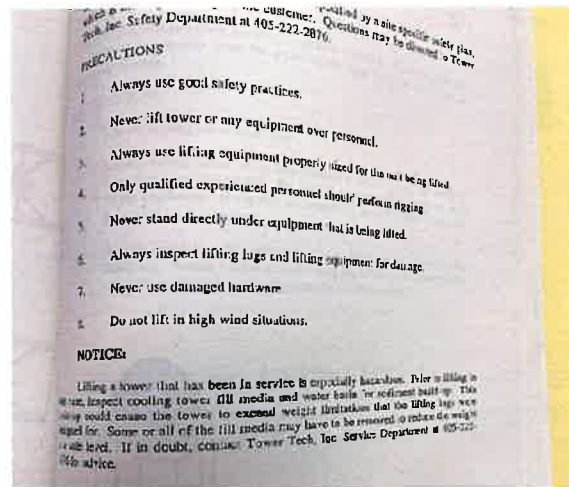

Please see the chart below for dry weights.

TOWER SERIES#	WEIGHT* LBS	L FT	I FT
TIMT-36	4,500	8	-
TIMT-72	5,600	10	-
TIMT-108	6,700	15	-
TIMT-144	7,800	15	-
TIMT-216	10,000	20	-
TIMT-288	12,200	25	-
TTMT-360**	14,400	15	24
TIMT-360	14,400	25	12

Question #19: During the pre-bid meeting it was mentioned that the owner does not plan to use ODP for the chillers. Is this correct?

Answer #19: Confirmed, the owner is not using ODP to purchase the chillers.

Question #20: Do we wish to flush the entire chilled water system through the campus or omit this from the scope?

Answer #20: See response to question #5.

Question #21: Is the owner keeping any of the old equipment? Is this correct? If the owner does want to keep any equipment, will someone from Facilities department provide transportation or does the contractor need to?

Answer #21: No. The owner is not claiming nor retaining any existing equipment so designated to be demolished on this project. The contractor shall remove from the site and dispose of all.

Question #22: Will we need to provide a flush pump to circulate the water and chemicals for the chilled water piping flush or will we be using the house pumps?

Answer #22: It is anticipated that a small circulator pump will be required to flush the new chilled water and condenser water pipe.

Question #23: On drawing M201 keynote 10, it is calling out the condenser water piping outside to be sch 80 PVC pipe, on the job walk it was said to be carbon steel pipe. Can you clarify?

Answer #23: Piping to be black steel.

Question #24: In the job walk it was mentioned that we would be trying to keep the existing cooling tower Ct-2 online that is feeding Chiller-3 for as long as possible. It looks like we will need to do at least one preliminary shutdown to cut in tees for the new upsized CHW piping and the CWR piping inside. Did not see a plan for the exterior CW supply and return piping demo and replacement. It looks like the existing piping is in the footprint of the new cooling tower support steel. Can you please ask the design team to help clarify these issues.

Answer #24: It is intended that the existing cooling tower (Tower Tech) and existing chillers remain in places for as long as possible. The new Cooling tower will be installed and as much of the new piping pre-assembled prior to shut down. During the summer, the college is closed Friday through Sunday, and the remaining work would be conducted at this time.

Question #25: Confirm 12" Equalizer line on Cooling Tower.

Answer #25: Confirmed.

Question #26: 10" Strainer – replace?

Answer #26: Confirmed to be replaced.

Question #27: Old Cooling Tower (**Tower Tech**) – Would like to keep in place and running during new tower install; this will help keep costs down vs hot tapping.

Answer #27: Concur.

Question #28: From the disconnect on the CWS/CWR P-C3 (E)P-C4 (E), and at the connection to the Piping that is existing from CH2 to the Tower Ct-2, Ct-1. Please confirm this is the only Piping to be Sch 80 PVC per note 10, on M201.

Answer #28: See response to Question #23.

Question #29: CWS/CWR Piping from New Chiller to be Sch 80 PVC. Confirm.

Answer #29: Piping to be black steel. Drawings to be updated.

Question #30: Drawing MD201 Note 8 indicates water treatment to be demo, Note 10 indicates it's to remain. Confirm we are leaving this in place.

Answer #30: Chemical treatment to be replaced with Nalco system.

Question #31: Several Notes such as Note 23(M002), Note G (M201 & M301) Indicate to flush and clean and loop at Coils. Please confirm. There is minimum Pipe CH/CHR between New Chiller, Pumps, and existing Building Close Loop. A clear flush with proper direction, and coordination with Water treatment Vendor, with the small amount of piping, should be adequate.

Also, new piping will be installed and clear water flush prior to connection to existing systems. We would anticipate the piping connections to all the existing systems would be coordinated to be done during off hours, To minimize interruption time to the facility. If looping is required and flushing the entire existing system. This will require a total shutdown and process for the facility and contractor to coordinate flush & clean. If this is required, please provide documents to show where Loops are required to accomplish this task and sizes.

Also, The velocity's(FPS) as indicated in note H, probably can't be done with current system in place.

Confirm Clear water flushing is adequate.

Answer #31: Only the new chilled water and condenser water pipe is to be flushed. Perform prior to connecting new equipment. SGM takes no exception to the recommended method of flushing.

Question #32: Please confirm equipment to be turned over to owner. If the owner doesn't want the Chiller, the refrigerant will need to be evacuated and disposed of or the owner could evacuate it, recover, and keep for future use at another existing facility if needed. Typically, this is what we see done.

Answer #32: The owner does not wish to retain any equipment. All equipment to be demolished and shall be disposed of by the contractor. Evacuate the refrigerant and provide it to the owner. Recovered cylinders used shall be clean, free of contamination and properly identified with the type of refrigerant and total weight of cylinders. Recovery cylinders, once accepted and transferred to the owner, will become property of owner.

Question #33: Confirm Cooling tower being turned over as well or disposed of.

Answer #33: Existing Tower Tech cooling tower is to be disposed of by the contractor.

Question #34: Documents indicating Painting of Pipe. Please confirm what is to be painted.

Answer #34: All exposed (non-insulated) pipes.

Question #35: Existing CHWR/CHWR is insulated and jacketed. M201 Note 15 indicates insulated only. Please confirm if Aluminum jacketing is required.

Answer #35: Aluminum jacketing only required for exterior piping.

Question #37: Please confirm Sump Equalizer line to be Sch 80 PVC.

Answer #37: Black steel pipe to be used.

Question #38: Note G (M201 & M301) indicates to flush and clean and loop at Coils. Please confirm this is needed.

Answer #38: Only new pipe to be flushed. Coordinate with Nalco.

Question #39: There is minimum Pipe CH/CHR between New Chiller, Pumps, and existing Building Close Loop. A clear flush with proper direction, and coordination with Water treatment Vendor, with the small amount of piping, should be adequate. Also, new piping will be installed and clear water flush prior to connection to existing systems. We would anticipate the piping connections to all the existing systems would be coordinated to be done during off hours, to minimize interruption time to the facility. If looping is required and flushing the entire existing system. This will require a total shutdown and process for the facility/ and contractor to coordinate to flush & clean. If this is required, please provide documents to show where Loops are required to accomplish this task and sizes. Also, The velocity's(FPS) as indicated in note H, probably can't be done with current system in place. Confirm Clear water flushing is adequate.

Answer #39: Concur.

Question #40: Confirm Cooling tower being turned over as well or disposed of.

Answer #40: Confirmed. The cooling tower is to be demolished and is to be disposed of by the contractor.

Question #41: Existing CHWR/CHWR is insulated and jacketed. M201 Note 15 indicates insulated only. Please confirm if Aluminum jacketing is required.

Answer #41: Aluminum jacketing only required on outdoor pipe. See keynote 11 on M-201.

Question #42: M201 Note 11 indicates to use aluminum jacketing on exterior pipe. If PVC Sch 80 is being used for CWS/CWR piping, is there any need to jacket, or only paint for UV protection?

Answer #42: Black steel pipe will be utilized. Revised drawings to be issued.

Question #43: Please confirm Sump Equalizer line to be Sch 80 PVC.

Answer #43: Black steel pipe to be used.

Question #44: Ref. Specification Section 23 08 00- Commissioning of HVAC Systems: There are several references in this section to Specification Section 01 91 13 – “General Commissioning Requirements” that was not provided. Please provide Specification Section 01 19 13 – General Commissioning Requirements.

Answer #44: Please disregard references to Section 01 91 13 and follow language in Section 23 08 00.

Please use the link below for updated drawings and chiller specifications:

https://sgmengineering0-my.sharepoint.com/:f/g/personal/chad_sgmengineering_com/EvM2IQMvTDZMicVj44jjoYwBFcKr0B_Ty8z3r2hjhFicTw?e=jMDIaG



**ST. JOHNS
RIVER
STATE COLLEGE**

BID-SJR-13-2023 Chiller Replacement Project – St. Augustine Campus

**Pre-Bid Meeting
January 25, 2024, at 9:30 a.m.
Building H, Room: H0218, St. Augustine Campus**

ATTACHMENT A

Please Print Clearly

Attendance Register

Name of Attendee	Representing Company Name	Phone Number	Email Address
Rich Davau	Foresight construction	407-953-0386	Rdavau@Foresight-ct.com
STEPHAN BURETTI	ARBA construction	904-386-2863	ESTIMARUB@ARBAconstruction.com
Paul Shealy	SCORPIO construction	904-403-9403	cgregory@scorpioco.com
Terry Thomas	STRSC	386-312-4110	terrythomas@strstote.edu
AS Wildersin	Cortez Heating & AC	904-598-2254	cswildersin@cortez-he.com
STEVE GARDNER	STR	386-312-4092	STEEVEN@STRSC.ORG
Mike Conroy	STRSC	386-312-4091	mikeconroy@strstote.edu
TOM REYNOLDS	STRSC	904-276-6763	TOMREYNOLDS@STRSC.ORG
Ingrid Robinson	SGM	407-767-5185	Ingrid@sgmengineering.com
Chad Barnett	Coker Industrial Contractors	904-599-2556	Chad.Barnett@CokerIndustrial.com